

0.8V Reference Ultra Low Dropout (0.2V@1.5A) Linear Regulator

FEATURES

- Ultra Low Dropout:
0.2V (typical) at 1.5A Output Current
- Low ESR Output Capacitor (Multi-layer Chip Capacitors (MLCC) Applicable
- 0.8V Reference Voltage
- High Output Accuracy:
±1.5% over Line, Load and Temperature
- Fast Transient Response
- Adjustable Output Voltage by External Resistors
- Power-On-Reset Monitoring on Both V_{CNTL} and V_{IN} Pins
- Internal Soft-Start
- Current-Limit Protection
- Under-Voltage Protection
- Thermal Shutdown with Hysteresis
- Power-OK Output with a Delay Time
- Shutdown for Standby or Suspend Mode
- Simple PSOP-8 Package
- Lead Free Available (RoHS Compliant)

DESCRIPTION

The FT560 is a 1.5A ultra low dropout linear regulator. This product is specifically designed to provide well supply voltage for front-side-bus termination on motherboards NB and VGA Card applications. The IC needs two supply voltages, a control voltage for the circuitry and a main supply voltage for power conversion, to reduce power dissipation and provide extremely low dropout.

The FT560 integrates many functions. A Power-On-Reset (POR) circuit monitors both supply voltages to prevent wrong operations. A thermal shutdown and current limit functions protect the device against thermal and current over-loads. A POK indicates the output status with time delay which is set internally. It can control other converter for power sequence. The FT560 can be enabled by other power system. Pulling and holding the EN pin below 0.3V shuts off the output.

TYPICAL APPLICATIONS

- Front Side Bus VTT (1.2V/1.5A)
- Note Book PC Applications
- Motherboard Applications

TYPICAL APPLICATION CIRCUIT

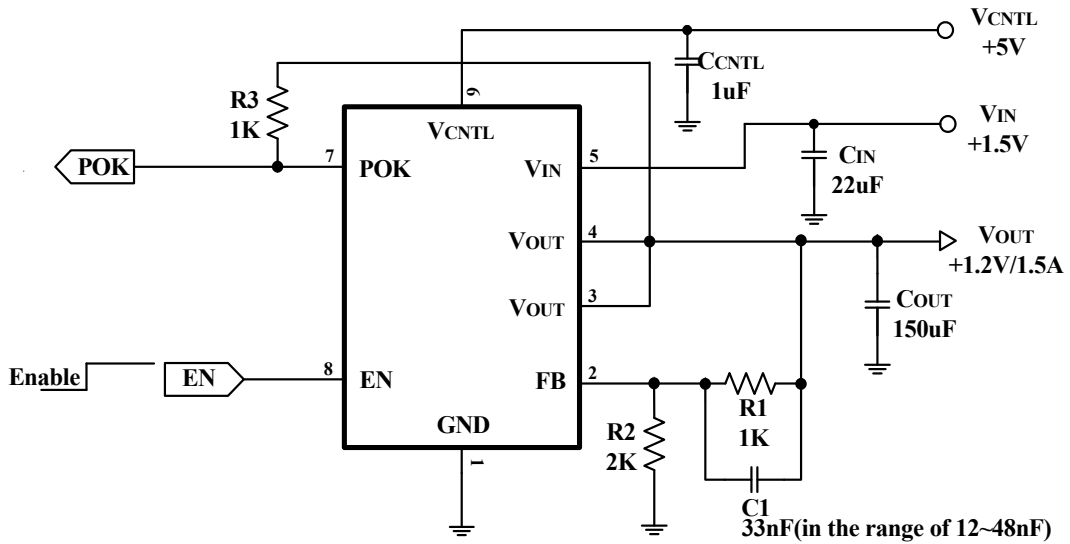

Figure1: Using an Output Capacitor with ESR \geq 18m Ω

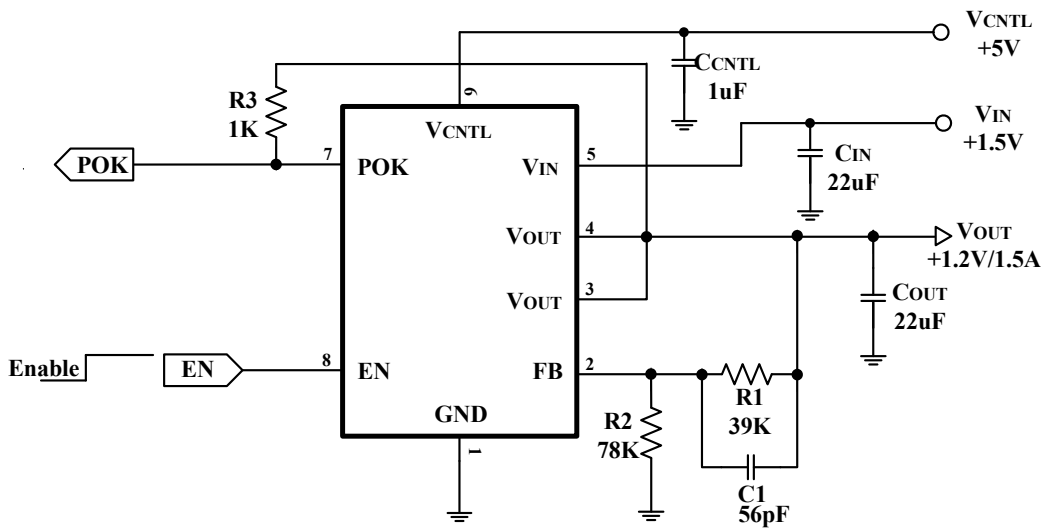

Figure2: Using an MLCC as the Output Capacitor

VOUT (V)	R1 (k Ω)	R2 (k Ω)	C1(pF)
1.05	43	137.6	47
1.5	27	30.86	82
1.8	15	12	150

Table1

ABSOLUTE MAXIMUM RATINGS

Symbol	Parameter	Rating	Unit
VCNTL	VCNTL Supply Voltage (VCNTL to GND)	-0.3~7	V
VIN	VIN Supply Voltage (VIN to GND)	-0.3 ~ 3.9	V
V _{I/O}	EN and FB to GND	-0.3 ~ VCNTL+0.3	V
VPOK	POK to GND	-0.3 ~ 7	V
P _D	Average Power Dissipation	2.8	W
P _{PEAK}	Peak Power Dissipation (<20mS)	20	W
T _J	Junction Temperature	150	°C
T _{STG}	Storage Temperature	-65 ~ 150	°C
T _{SDR}	Soldering Temperature, 10 Seconds	260	°C
V _{ESD}	Minimum ESD Rating (Human Body Mode)	±2	kV

Table 2

Stresses exceeding Maximum Ratings may damage the device. Maximum Ratings are stress ratings only. Functional operation above the Recommended Operating Conditions is not implied. Extended exposure to stresses above the Recommended Operating Conditions may affect device reliability.

THERMAL CHARACTERISTICS

Symbol	Parameter	Value	Unit
θ _{JA}	Junction-to-Ambient Thermal Resistance in Free Air (Note)	44	°C/W

Table3

Note : θ_{JA} is measured with the component mounted on a high effective thermal conductivity test board in free air. The exposed pad of PSOP-8 is soldered directly on the PCB.

PIN CONFIGURATION

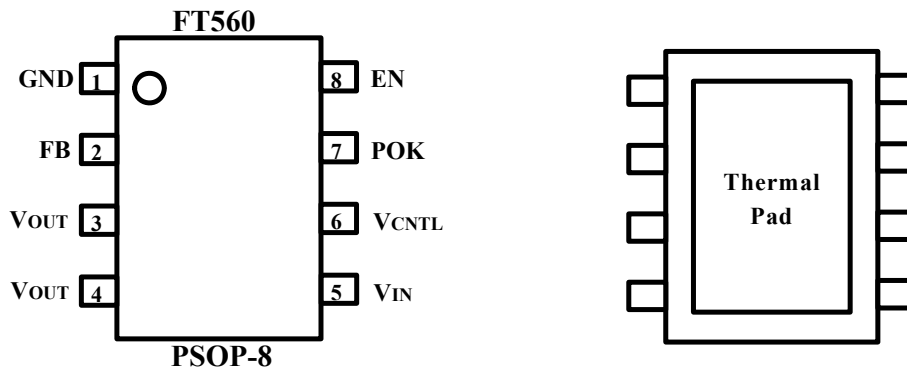

Figure 3: Pin Assignments

MARKING RULE

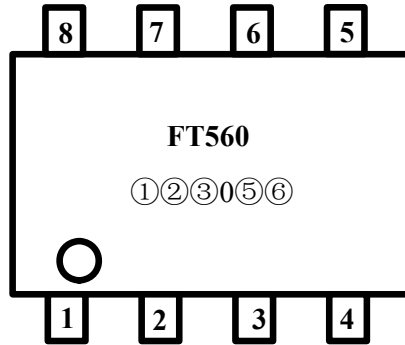

Figure 4: PSOP-8 (Top View)

- ① Represent Year
- ② Represent Week
- ③ Represent Lot
- ④ Represent Vacant
- ⑤ Represent Manufactory
- ⑥ Represent Version

RECOMMENDED OPERATING CONDITIONS

Symbol	Parameter	Range	Unit
VCNTL	VCNTL Supply Voltage	3.1 ~ 6	V
VIN	VIN Supply Voltage	1.1 ~ 3.3	V
VOUT	Output Voltage	VCNTL=3.3±5%	0.8 ~ 1.2
		VCNTL=5.0±5%	0.8 ~ VIN-0.2
IOUT	VOUT Output Current	0 ~ 1.5	A
TJ	Junction Temperature	-40 ~ 125	°C

Table4

APPENDIX A: REVISION HISTORY

Version A0: Original data sheet for the FT560.

Information furnished is believed to be accurate and reliable. However, Intelligent Embedded Solutions(IES) assumes no responsibility for the consequences of use of such information or for any infringement of patents of other rights of third parties which may result from its use. No license is granted by implication or otherwise under any patent rights of Intelligent Embedded Solutions(IES). Specifications mentioned in this publication are subject to change without notice. This publication supersedes and replaces all information previously supplied Intelligent Embedded Solutions(IES) products are not authorized for use as critical components in life support devices or systems without express written approval of Intelligent Embedded Solutions(IES). The IES logo is a registered trademark of Intelligent Embedded Solutions(IES). All other names are the property of their respective owners © 2010 Intelligent Embedded Solutions.-All rights reserved **www.iesdistribution.com**